

LiDAR Robot Vacuum & Mop

with auto-disposal station

magivaac®
RV4200

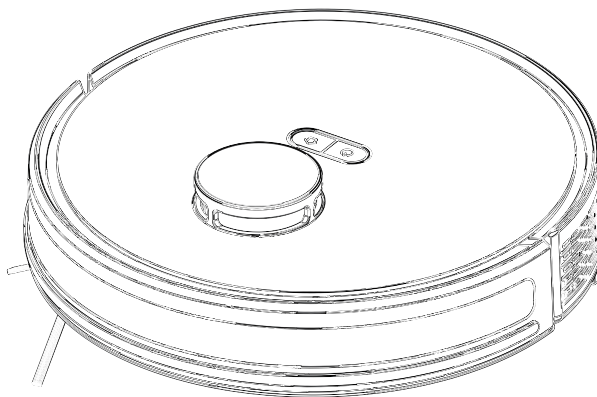

Batch: PR5318

Carefully read all instructions before use and save for future reference.

Contents

- About Robot Vacuum Cleaner ----- 01
- Installation ----- 05
- App Connection ----- 09
- Operation Instructions ----- 11
- Routine Maintenance ----- 15
- Basic Parameters ----- 18
- Common Problems ----- 19
- Troubleshooting ----- 20
- Safety Information ----- 21

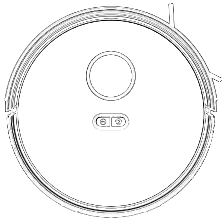

Robot Vacuum Cleaner

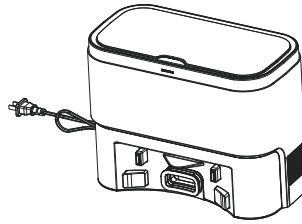

Auto Disposal Station

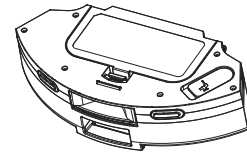

2 IN 1 Dust Box and Water Tank



Side Brush

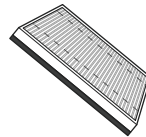

Filter

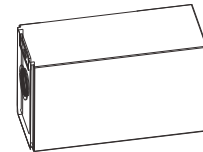

Dust bag

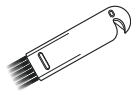

Cleaning Brush

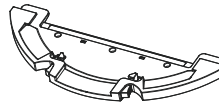

Mop Holder



Mop

About Robot Vacuum Cleaner

Main unit

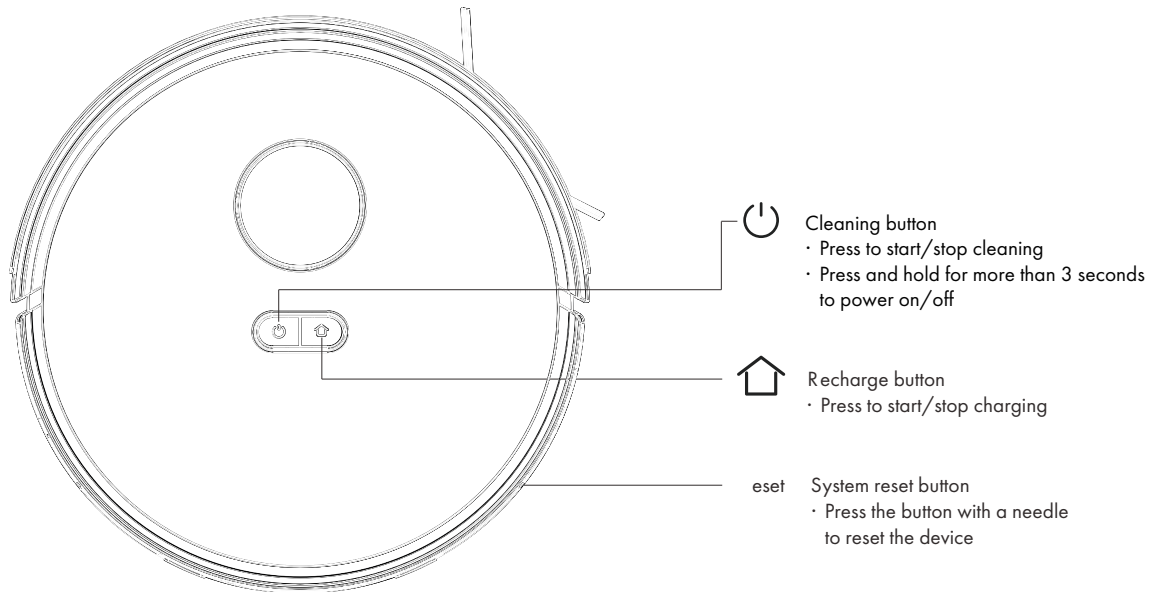

About Robot Vacuum Cleaner

Sensors and Structure

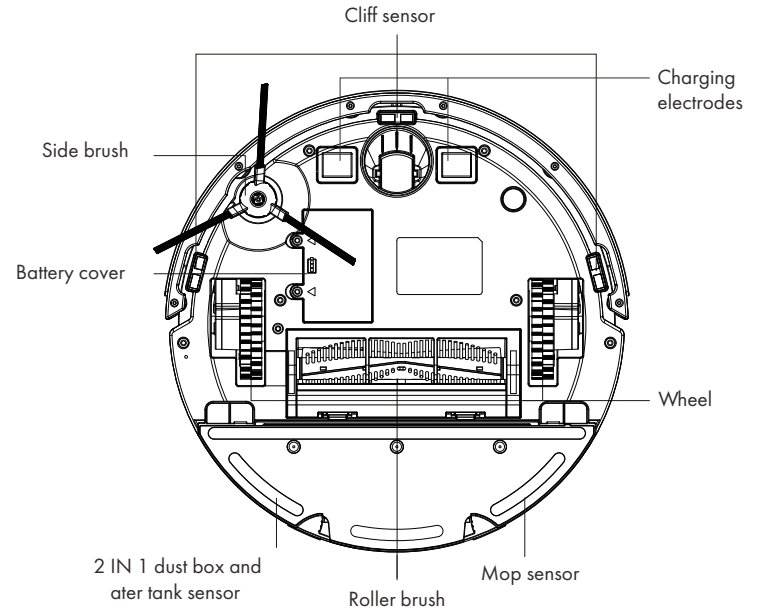
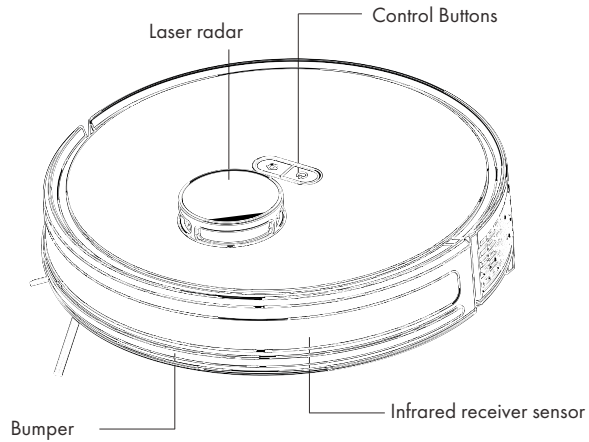

About Robot Vacuum Cleaner

2 IN 1 dust box and water tank

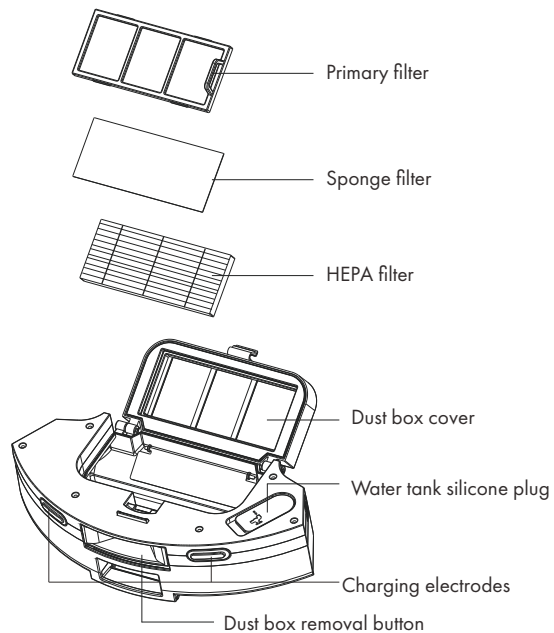

Dust collection station

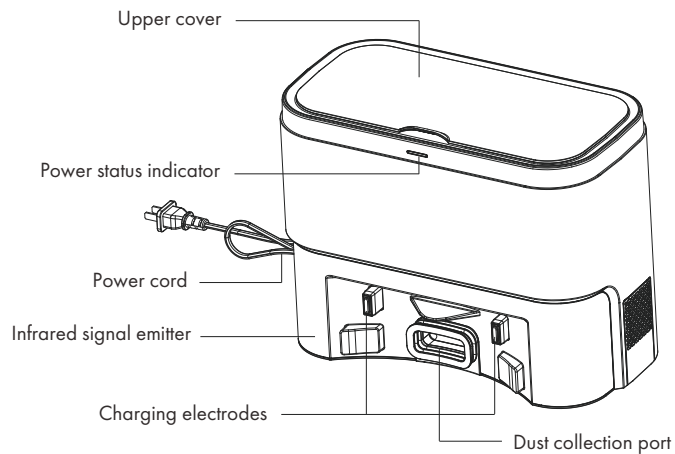

Installation

Precautions

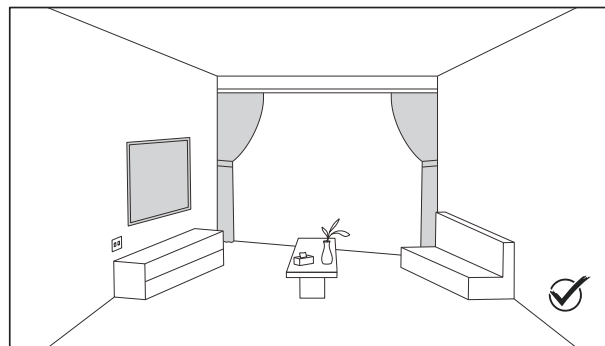
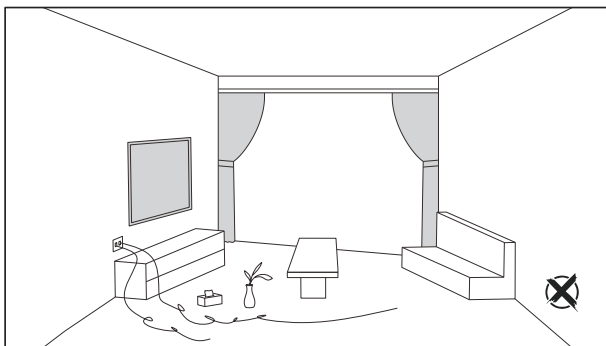

Before starting the machine, clear away any wires, debris, and objects scattered on the floor. Remove items that are fragile, valuable or prone to falling. Avoid situations where the machine could become entangled, stuck, dragged, or could knock over objects, as this may cause personal injury or property damage.

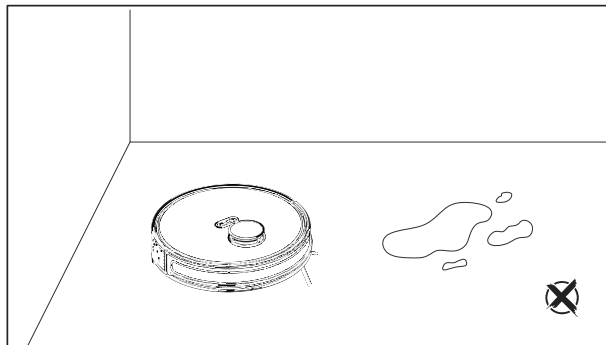

Don't use the machine to clean liquids.

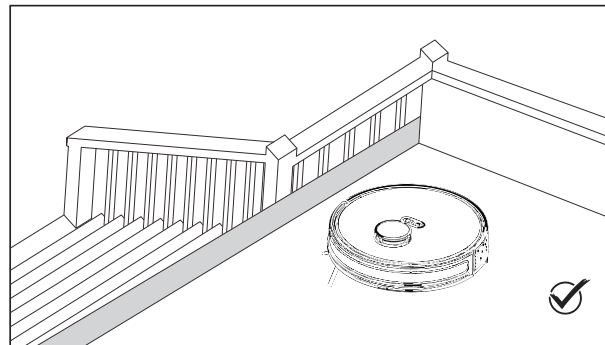

In areas like the top of stairs or where cleaning is prohibited, use the app to set up a virtual wall after mapping to prevent accidental falls or damage.

Installation

1. Remove protective materials from both sides of the robot vacuum cleaner as illustrated below.

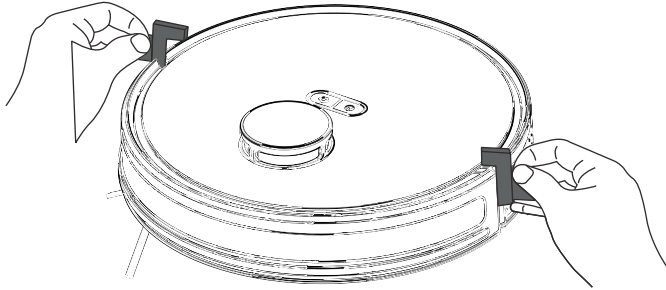

2. Install the side brush

Align the side brush with the side brush hole on the bottom and press down. You will hear a “click”, which means the side brush is installed in place.

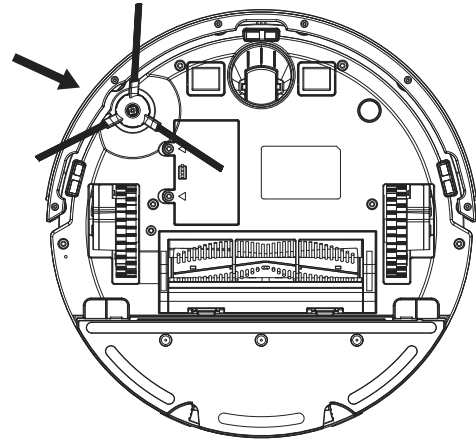

Installation

3. After connecting the power cord to the power source, tidy up any excess wires.

4. Place the charging station on a flat surface against a wall and connect it to a power source.

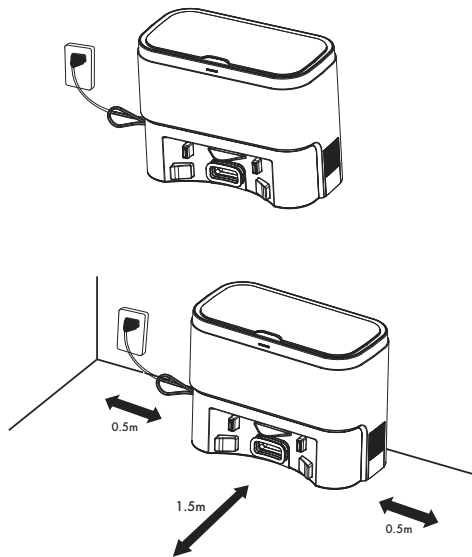

Note:
The indicator light stays on when the charging station is powered on and goes off when the machine is being charged.

5. Do not move the charging station and avoid direct sunlight.

Note:
Sunlight may interfere with the charging signal, preventing the machine from returning to the charging station.

6. Power on and charge

Press the power button to turn on the machine. When the indicator light is on, place the machine on the charging station to charge. When you hear the "Start Charging" sound, it means the machine is charging successfully.

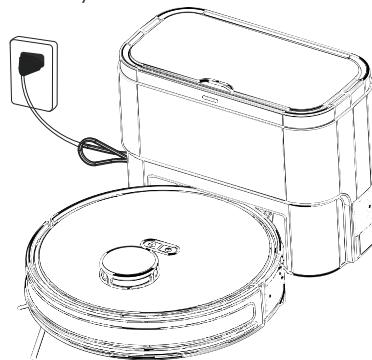

If the battery is low, the machine won't turn on. Place the machine on the charging station and the device will automatically power on.

Installation - Mopping function

1. Open the water filling cap, add an appropriate amount of water and then close the cap tightly. **Do not add any detergent.**

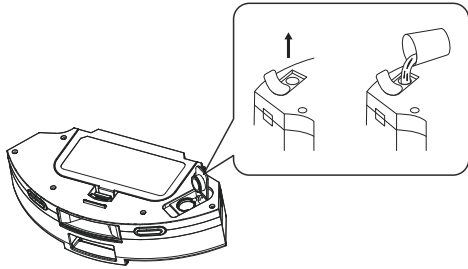

2. Install the 2 in 1 dust box and water tank onto the machine.

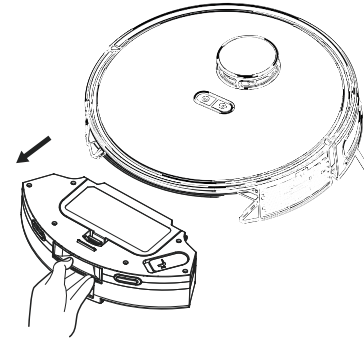

3. Install the mop on the mop holder

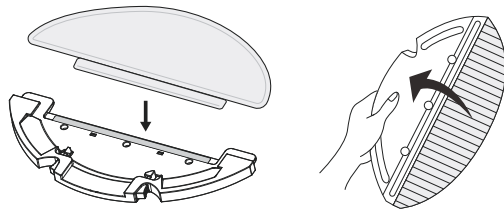

4. Install the mop holder.



App Connection

Preparation

Download the app

Scan the QR code to download the app, or search for "Smart Life" or "Tuya Smart" in the Google Play or Apple App Store. Then, simply install it on your device and log in or create an account.

Please note that only 2.4GHz networks are supported.

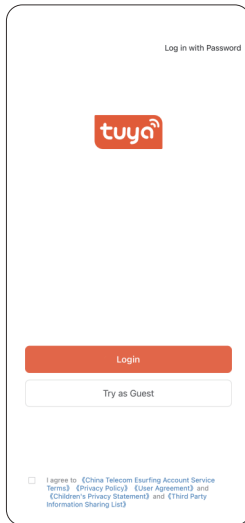

1. Register and log in to the app.

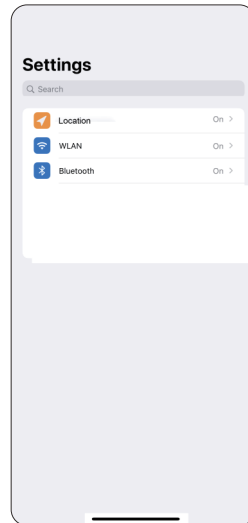

2. Turn on mobile phone positioning, WiFi and Bluetooth, and authorise the app to access WiFi and Bluetooth.

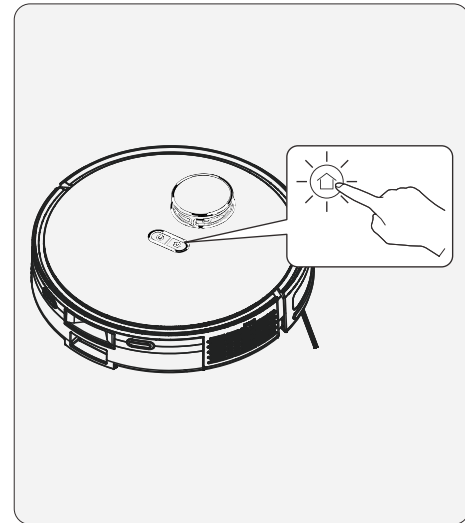

3. Power on the machine. Press and hold the recharge button for more than 3 seconds until the voice prompt/indicator light flashes quickly, indicating that the machine enters the network pairing mode.

App Connection

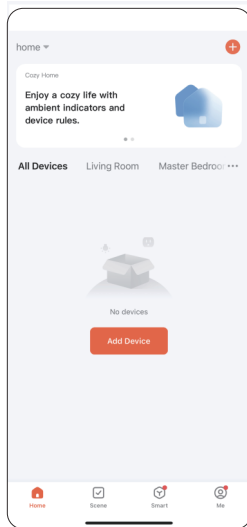

4. Click "Add Device" or "+" in the top right corner.

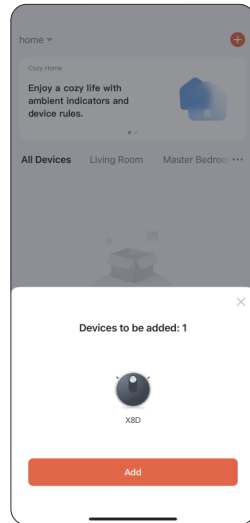

5. Add the found device.

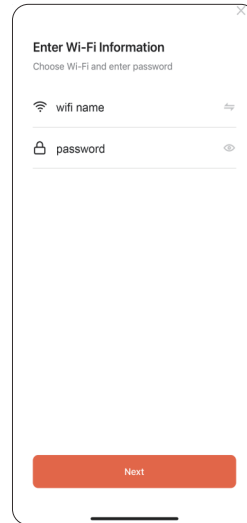

6. Connect to 2.4GHz WiFi network and enter the required WiFi information.

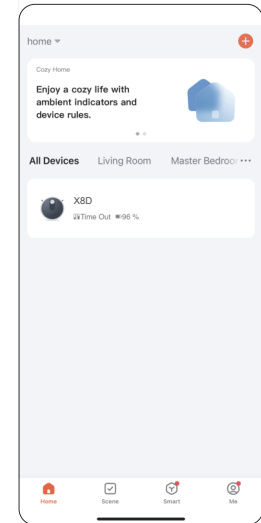

7. Complete connection.

Operation Instructions

Power ON/OFF

Press and hold the power button on the machine for more than 3 seconds. If the machine is off, an indicator light or voice announcement will confirm that it has successfully turned on. In standby mode, the indicator light will turn off or a voice announcement will confirm that the machine has been successfully shut down.

Clean/Pause

Press the power button on the machine or the cleaning button in the mobile app to start cleaning. Press the button again to pause.

Recharge/Stop

Press the recharge button on the machine or in the mobile app to start charging.
Note: If the robot vacuum cannot locate the charging station, it will automatically return to its starting position. Please manually place the unit on the charging station to begin charging.

Reset

Press the reset button with a needle to reset the machine.

Operation Instructions - Cleaning mode

Smart cleaning

The machine scans the work environment, generates a map and intelligently divides areas. Once cleaning is complete, the machine returns to the charging station to recharge.

In order to map better, the machine needs to clean for the first time starting from the charging station.

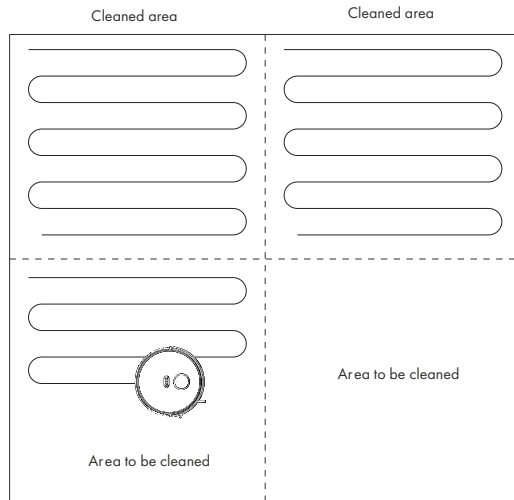

Note: Do not move the machine too often during operation. If you need to move it, place it near its original location. When restarted, the machine will try to reposition itself. If it succeeds, it will continue according to the planned path. If it fails, the device will abandon the previous task, create a new cleaning map, and may be unable to charge.

Spot cleaning

Choose a point on the map, and the machine will move to the designated location and clean a square area of 1.6m x 1.6m centred on itself.

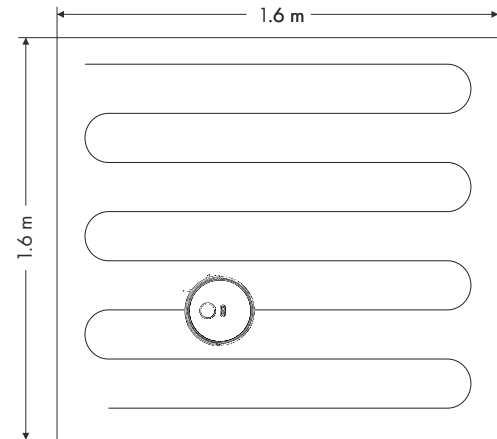

Note: Before using this function, complete one full cleaning cycle to create a map of your space in the mobile app.

Operation Instructions - Cleaning mode

Cleaning of selected area

Use the mobile app to choose the cleaning function for the selected area.
Select the rooms you want to clean on the map, and the machine will clean the chosen rooms.

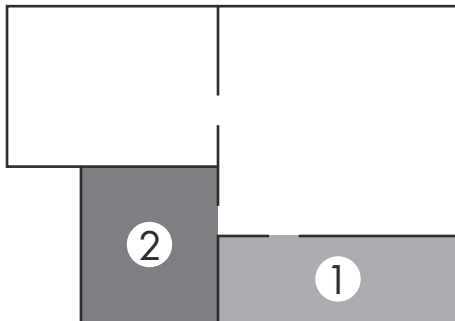

Cleaning of defined area

Use the mobile app to choose the cleaning function for the defined area.
Select the area to be cleaned on the map and the machine will clean the chosen area.

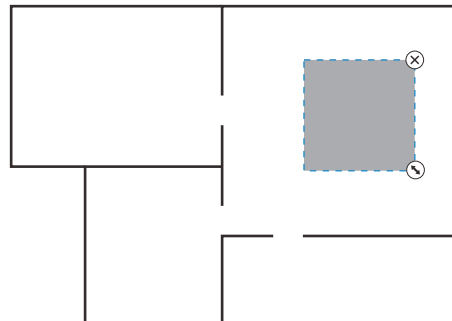

Note: Before using these functions, complete one full cleaning cycle to create a map of your space in the mobile app.
The machine may enter unplanned areas, so please remove any obstacles around the planned cleaning area to ensure it operates safely.

Operation Instructions - Cleaning mode

Map editing

Use the mobile app to select the virtual wall editing function. Add and set (can be dragged and lengthened/shortened) on the map the virtual wall that the machine will avoid when cleaning.

Note: Before using this function, complete one full cleaning cycle to create a map of your space in the mobile app.

This function is designed solely for defining cleaning areas and cannot be used to block dangerous areas. If the machine or dock is moved, or if there are significant changes to the home environment, the map may become invalid, and restricted areas may be lost.

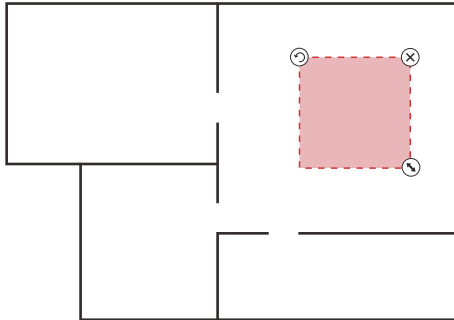

Routine Maintenance

Roller brush (recommended cleaning frequency: once a week)

1. Turn the machine over, press the button on the roller brush cover and remove the cover.

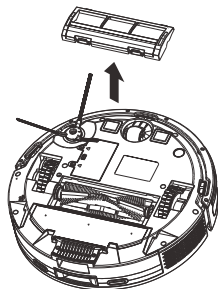

2. Remove the roller brush.

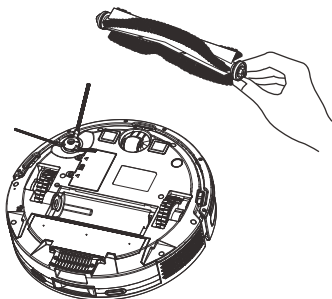

3. Use a cleaning brush to remove dust from the cavity, and remove entanglements on the roller brush.

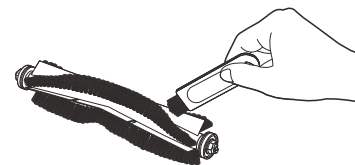

Side brush (recommended cleaning frequency: once a week)

1. Turn the machine over and remove the side brush by pulling upward.
2. Remove any tangled hair.
3. Align the side brush with the side brush hole on the bottom, then press down to replace the side brush.

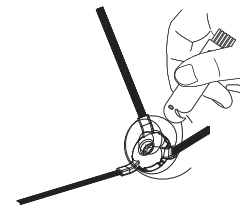
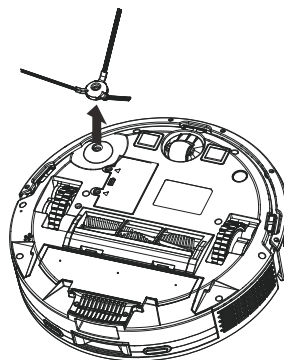

Note: For optimal cleaning performance, it is recommended to replace the side brush every 2-3 months and the roller brush every 6 months.

Routine Maintenance

Dust box and filter (recommended cleaning frequency: after each use)

1. Press the dust box button and pull out the dust box.
2. Press the switch on the dust box to open the dust compartment and empty it.

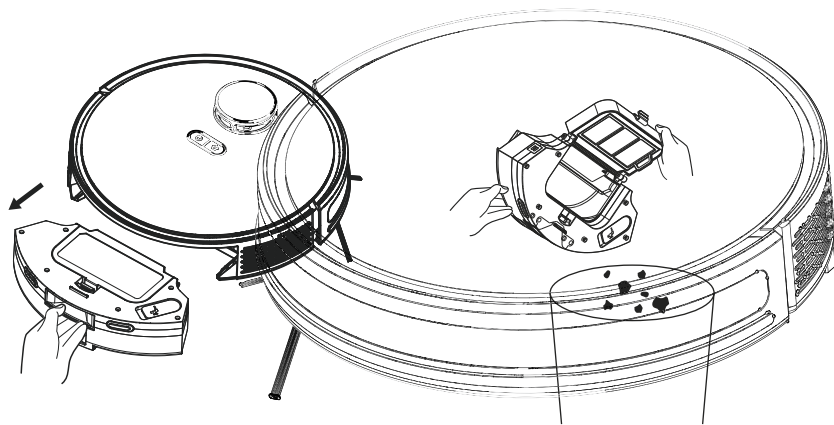

Wash 2 in 1 Dust box and water tank

1. After prolonged use remove the sponge and HEPA filters.
2. Rinse the primary filter, dust box and sponge under a tap.
HEPA filter cannot be rinsed with water.
3. After cleaning, shake off the water droplets, air dry the filters and dust box and wait until they are completely dry before use.

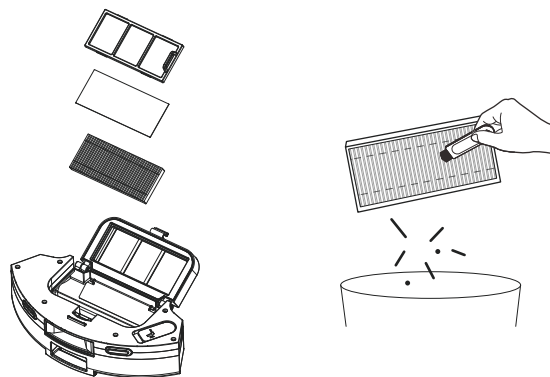

Note: Wash with clean water only without adding any detergents.
Never use a hard brush or fingers to clean the HEPA filter.
Washed filters should be air dried for at least 24 hours to allow them to dry thoroughly. It is recommended to replace the HEPA filter every 3 months.

Routine Maintenance

Clean the infrared obstacle avoidance sensor.
Recommended cleaning frequency: once a month.

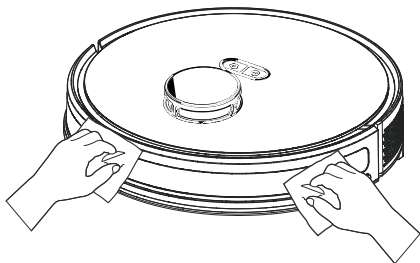

Clean the cliff sensor.
Recommended cleaning frequency: once a month.

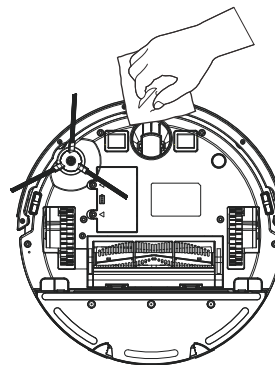

Clean the charging electrodes.
Recommended cleaning frequency: once a month.

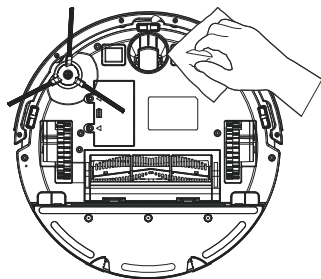

Clean the charging station.
Recommended cleaning frequency: once a month.

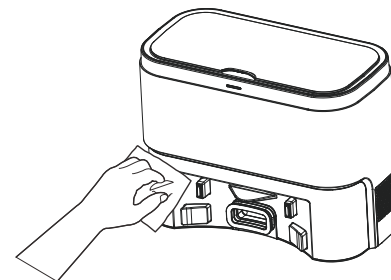

Routine Maintenance

Battery

- The robot vacuum has a built-in rechargeable high-performance lithium-ion battery pack. To maintain best battery performance, please keep the machine charged during daily use.
- If the machine is not use for a long time, it should be shut down for storage and charged every three months to avoid battery damage.

Firmware upgrade

Enter the firmware upgrade function through the mobile app. After detecting the new firmware, upgrade according to the prompts. When upgrading, the machine must be placed on the charging station for charging. It is recommended that the battery capacity be not less than 50% before upgrading.

Basic parameters

Host	Parameter
Model no	RV4200
Size	Φ320x97mm
Battery	4000mAh lithium-ion battery
Rated voltage	14.8 V $\overline{=}$
Rated power	33W
Charging time	4-5 hrs
Dust box capacity	230ml
Water tank volume	240ml

Dust collection station	Parameter
Size	320x165x240mm
Rated voltage	AC 230V~
Rated power	1000W

Common Problems

PROBLEM	SOLUTION
Failed to power on the machine	<ul style="list-style-type: none"> - Insufficient power. Please place the machine on the charging station. The machine will automatically power on. - Ambient temperature is too low or too high (below 0° or above 40°). Please use the machine when the ambient temperature is between 0° and 40°.
Failed to charge the machine	<ul style="list-style-type: none"> - Move the machine away from the charging station, check whether the indicator light of the charging station is on, and ensure that both ends of the power adapter are connected correctly. -There is poor contact between the charging station and the machine. Please clean the charging electrodes.
Failed to return to charging station	The machine is too far from the charging station, try placing the machine near the charging station.
Abnormal behaviour	Turn the machine off and on again.
Abnormal noise during cleaning	The roller brush, side brush or wheel may be entangled. Please stop the machine and clean it.
The cleaning performance has degraded/ machine is dropping dirt	<ul style="list-style-type: none"> - Clean or replace the filter. -The dust box is full, empty and clean the dust box. -The roller brush is entangled. Clean the roller brush.
Failed to connect WiFi	<ul style="list-style-type: none"> - WiFi signal is not good, move the machine to a location with good WiFi signal. -The WiFi connection is abnormal, reset WiFi settings, download the latest version of the app and then reconnect. -Incorrect password. -Machine supports only 2.4GHz networks.
Failed to perform scheduled cleaning	The battery is low, the scheduled cleaning will only start when the remaining battery reaches more than 15%.
If the machine remains on the charging station, will it consume electricity?	When the machine remains on the station, power consumption is extremely low, which helps maintain optimal battery performance.
Do I need to charge the battery for 16 hours the first three times I use the machine?	Lithium batteries have no memory effect and can be used immediately after being fully charged without waiting.

Troubleshooting

Host failure

ERROR PROMPT	SOLUTION
Error 1: Inserting the 2-in-1 dust box/water tank	Cleaning is triggered when taking out the 2-in-1 dust box/water tank, please reinstall the 2-in-1 dust box/water tank.
Error 2: Place the machine on the floor before starting	Pick up the machine or the machine is suspended. Please move the machine to a flat surface and restart it.
Error 3 : Please lay the machine flat on the ground and start it	The machine is tilted. Please move the machine to a flat surface before starting it again.
Error 4 : Please check whether the front bumper is stuck	The edge or collision sensor is stuck. Please push the bumper to the left to confirm that it is not stuck.
Error 5 : Low battery, please charge	Place the machine on the charging station to charge.
Error 6 : The machine is trapped	Please move the machine to an open area and start the machine.
Error 7 : Please check whether the wheel is stuck	The wheel is stuck or entangled. Please check the wheel and remove foreign matter.
Error 8 : Please check whether the roller brush is stuck	The roller brush is entangled or struck. Please check the roller brush and remove foreign matter.
Error 9 : Please check whether the side brush is stuck	The side brush is entangled or struck. Please check the side brush and remove foreign matter.

Dust collection station failure

ERROR PROMPT	SOLUTION
Error 1: Indicator light: white light flashes once, orange light flashes once - dust bag is not installed in the dust collection station.	Install dust bag in the dust collection station
Error 2: Indicator light: white light flashes once, orange light flashes 2 times - the dust collection station cover is not closed or the dust bag is full.	Close the upper cover or replace the dust bag

Safety Information

Use Restrictions

1. This product should only be used for household floor cleaning.
2. Do not use it outdoors (such as on an open-air balcony), off the ground (such as on a sofa), or in a commercial or industrial environment.
3. Do not use the machine in suspended environments without guardrails (such as duplex floors, open balconies and on top of furniture).
4. Do not use this machine in an environment where the temperature is higher than 40°C or lower than 0°C, or where there are liquids and sticky objects on the ground.
5. Please place fragile items and debris (such as vases, packaging bags, etc.) on the ground, otherwise they may block the machine or cause minor collisions, damaging valuable items in your home.
6. Do not allow persons with physical, mental or sensory impairments, including children to use or operate this product.
7. Do not allow children to use the machine as a toy. Please keep children and pets away from the machine when it is working.
8. Please keep the cleaning brush out of the reach of children.
9. Never place any objects (including children and pets) on stationary or moving machine.
10. When the machine is working, please keep hair, fingers and other parts of the human body or pets away from the machine's vacuum inlet.
11. Do not use the machine to clean burning materials, such as burning cigarette butts.
12. Do not use the machine to clean high-pile carpets.
13. Do not use this machine to vacuum hard or sharp objects such as glass, nails, etc.
14. Do not use the protective cover or bumper of the laser distance sensor as a handle for carrying the machine.
15. Please clean or maintain the machine and charging base when the machine is turned off or powered off.
16. Do not use a wet cloth or any liquid to wipe any part of the machine.
17. When using the machine, follow the instructions in the manual.
18. Any losses and injuries caused by improper use are the sole responsibility of the user.
19. Do not use the mopping function on carpets or furniture.
20. Please remove the mop holder and mop when charging the machine.

Battery and Charging

1. Do not use any third-party battery, charging station or adapter.
2. Do not disassemble, repair or modify the battery or charging station without permission.
3. Do not place the charging station near heat sources such as radiators.
4. Do not use a wet cloth or wet hands to wipe or clean the charging station electrodes.
5. Dispose of used batteries properly and send them to a professional recycling facility.
6. If the power cord is damaged or broken, please stop using it immediately and purchase a new power cord from Lennox Customer Service.
7. If the machine will not be used for a long time, please turn off the power after it is fully charged and place it in a cool and dry place.
8. The machine should be charged at least once every three months to avoid battery damage due to over-discharge.
9. When transporting the product, make sure the machine is turned off and it is recommended to use the original packaging box for packaging.

LENOXX

www.lenoxx.com.au

 1300 666 848

 LenoxxElectronics

 LenoxxElectronics

service@lenoxx.com.au