

V. Note:

Always use the appliance in a well ventilated area.

Do not use the fryer without the adequate amount of oil.

Do not allow children or people without authorization use the fryer in order to avoid an accident.

You must unplug the power supply cord or cut off power switch if you are not using the machine.

All service and maintenance must be carried out after the power supply is cut off. If there are problems with the fryer, do not dismantle the machine send it to your supplier's service department for repair.

⚠ WARNING:

- Using old oil will lower the flash point and will cause it to boil over easily.
- It may also cause a fire .
- Always ensure the oil is between the min and max points.
- Care should be taken when frying over-wet food.

VI.Circuit Diagram:

220~240V/50Hz-60Hz

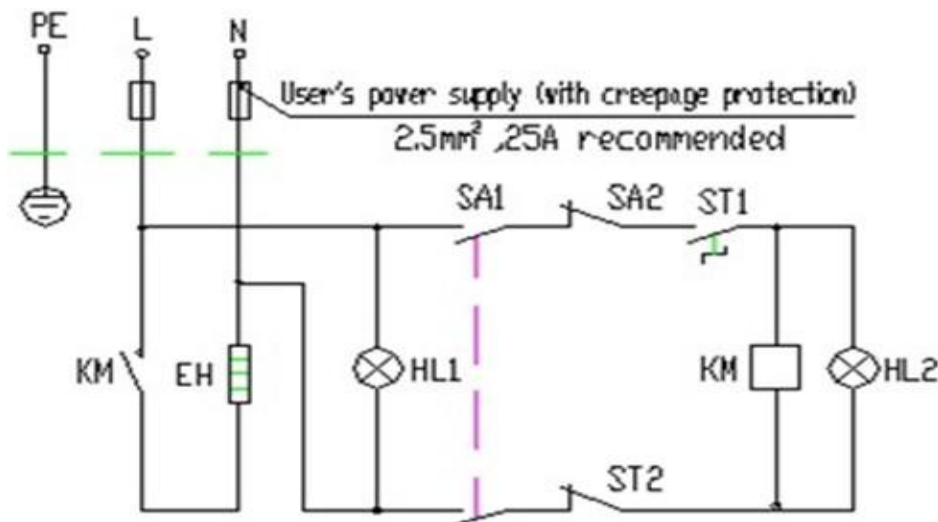

SA1:Power Switch SA2:Safe Switch ST1:Temperature Controller ST2:Limit Temperature

HL1:Power Indicator HL2:Heating Indicator EH: Heating Element KM:Power Relay



Electric Fryer

Instruction manual

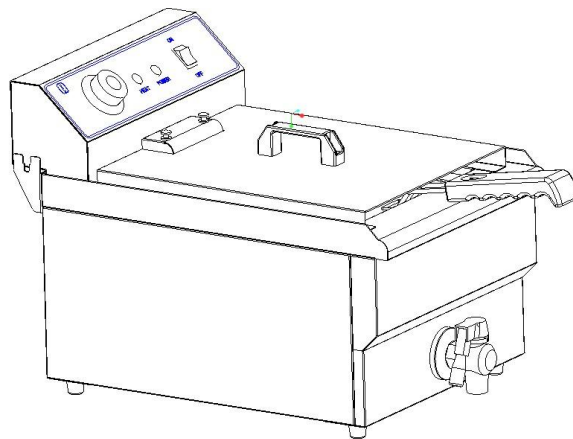

CDF-DR10-SINGLE-SI

- ★All stainless steel construction
- ★Automatic thermostat
- ★Efficient and easy to operate
- ★Durable and elegant design
- ★Must have someone to supervise when using this product, to cut off the power when leaving

Table of Contents

Section	Page
Introduction	3
Technical Specification	3
Operating Instruction	3
Maintenance	3
Notes	4
Circuit Diagram	4



I .Introduction:

EF Series Fryer is a new kind of catering fryer. Made from good quality stainless steel which is stylish, durable and easy to clean. The products are equipped with highly reliable components so that they are energy-saving and safe.

The featured design of a removable fryer head offers convenience, practicality and cleans easily. The EF series provides a thermostat function, for quick and constant temperature control.

II. Technical Specification:

Model	Voltage	Input Power (kW)	Capacity (L)	Capacity Of Pouring Into Oil(L)	Dimension (mm)	N.W. (kg)
CDF-DR10-SI NGLE-SI	220~240V/ 50HZ	3	10	8	475X271X337	7.7

III. Operating Instruction:

Before use please check whether the voltage of power supply is in conformity with your power supply.

Operation Step:

1. Fill the oil tank to the correct level on your appliance.
2. Connect with fryer's power supply and green power indicator will come on.
3. Adjust temperature control to a suitable temperature in a clockwise manner.
4. When the yellow indicator is on the heating element will begin to heat.
5. When oil temperature reaches the required temperature the temperature control will cut the power-off, the yellow indicator will turn off and the heating element stop working. When oil temperature drops, the temperature control connects power supply automatically, the yellow indicator turns on, and the element heat again. This procedure is repeated to ensure oil temperature stays set at the desired temperature.
6. There is a frying basket provided with your fryer. When you finish frying the food there is a special hook to drain away any excess oil for better quality frying.
7. The cover is designed to keep the oil clean and warm. Pay attention to make sure that there is no water on the cover before you close cover.
8. After you finish frying be sure to turn your appliance off.
9. The fryer is equipped with safety switch. When you lift up the electric control box and the heating element is out from oil, the safety switch will take action the cut off power.
10. The temperature limited device will operate and cut off the heating element when the oil temperature is too high while using. Please check the machine after the power is cut off and the oil is cooled down to room temperature. Then open the cover of the reset button behind the control box and press the reset button to restart the machine.

IV. Maintenance:

After use, you should use a wet cloth to clean. DO NOT IMMERSER IN WATER. Please ensure you remove all oil covered parts carefully and consistently. This will prolong the life of your fryer.