项目名称

W2449A

版本号

A04

设计时间

2026/03/03

物料名称

说明书

设计师

文案

常思敏

周佳乐

审核

批准

料号

04170500008992

材质工艺要求:

材质要求: 70g 双胶纸 骑马钉

颜色及专色: K 100

尺寸要求: 140mm*210mm

变更履历:

A01- 删除二维码 / 改吸水模式 / 改清洁液话术变更

A02- 更改售后信息

A03- 更改中间页 (Troubleshooting 表格下面两行字) 售后信息

A04- 加 SOC 文件

H15 Pro Heat

Wet and Dry Vacuum

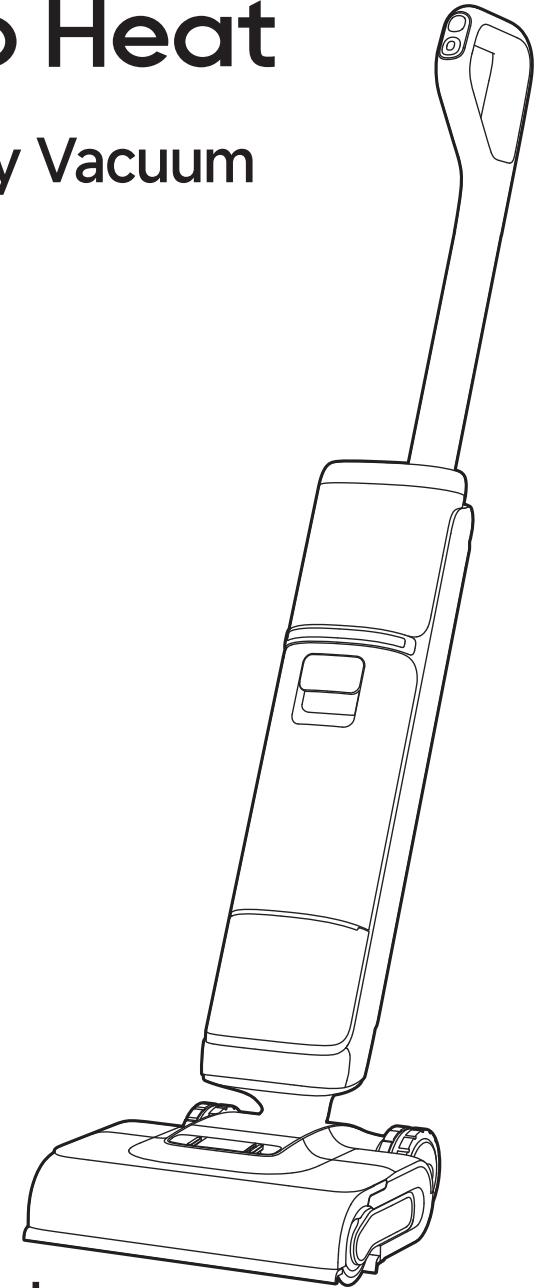

Website: <https://dreame.com.au>
Manufactured by: Dreame Trading (Tianjin) Co.,Ltd.
Made in China



User Manual

The illustrations in this manual are for reference only. Please refer to the actual product.

DREAME

THANK YOU

FOR PURCHASING THIS DREAME
WET AND DRY VACUUM

The high-quality product is engineered for optimal performance.

If you have any questions on the product, please contact us:

Australia:

Email: support.au@dreame.tech

Hotline: (02) 8488 1036

New Zealand:

Email: support.nz@dreame.tech

Contents

Important Safety Instructions	01
Product Overview	03
Installation & Charging	05
Connecting with Dreamehome App	06
Starting Cleaning	07
Display Screen	08
Emptying the Used Water Tank	09
Self-Cleaning with Hot Water &Drying Mode	10
Care & Maintenance	11
Troubleshooting	13
Error Prompts and Solutions	15
Specifications	15
Battery Disposal and Removal	16



Please scan the QR code for the User Manual.

Important Safety Instructions

Please read this manual carefully before use and retain it for future reference.

When using an electrical appliance, basic precautions should always be followed, including the following:

READ ALL INSTRUCTIONS BEFORE USING (THIS APPLIANCE). Failure to follow the warnings and instructions may result in electric shock, fire and/or serious injury.

WARNING — To reduce the risk of fire, electric shock, or injury:

Usage Restrictions

- This appliance should not be used by children younger than 8 years old nor persons with physical, sensory, intellectual deficiencies, or limited experience or knowledge without the supervision of a parent or guardian to ensure safe operation and to avoid any risks. Cleaning and maintenance shall not be performed by children without supervision.
- Plastic film can be dangerous. To avoid the danger of suffocation, keep it away from children. Children shall not play with the appliance.
- Use indoors only, on non-carpeted floor surfaces such as vinyl, tile, sealed wood, etc. Be careful not to run over loose objects or the edges of area rugs. Stalling the brush may result in premature belt failure.
- Use only as described in this user guide. Use only manufacturer's recommended attachments.
- Do not expose the appliance to fire or excessive temperature. Exposure to fire or excessive temperature may cause an explosion.
- Do not use in extremely hot or cold environments (below 5°C/41°F or above 40°C/104°F). Please charge the appliance in temperature above 5°C/41°F and below 40°C/104°F.
- Do not immerse the appliance in liquid.
- Do not use to pick up flammable or combustible liquids, such as gasoline. Do not use in areas where flammable or combustible liquids may be present.
- Do not put any object into openings. Do not use the appliance when any opening is blocked. Keep free of dust, lint, hair, and anything that may inhibit air flow.
- Do not pick up toxic material (chlorine bleach, ammonia, drain cleaner, etc.). Do not pick up hard or sharp objects such as glass, nails, screws, coins, etc.
- Do not use the appliance in an enclosed space filled with vapor given off by oil-based paint, paint thinner, some moth-proofing substances, flammable dust, or other explosive or toxic vapour. Do not pick up anything that is burning or smoking, such as cigarettes, matches or hot ashes.
- Do not use the appliance without filters in place.
- Keep hair, loose clothing, fingers, and all parts of the body away from openings and moving parts of the appliance and its accessories.
- Keep ground cables away from the appliance when using it. A hazard may occur if the appliance runs over a supply cord.
- Use extra care when cleaning on stairs.

Important Safety Instructions

Maintenance and Storage

- Prevent unintentional starting. Ensure the switch is in the OFF-position before picking up or carrying the appliance. Carrying the appliance with your finger on the switch or turning on the appliance may result in an accident.
- Ensure that the appliance is placed on a horizontal surface. Do not use the appliance at the same position if the appliance is equipped with a brush roller and the handle is not completely upright. Do not store the appliance in a place where it may freeze.
- Switch off and unplug the appliance when not in use, before cleaning, maintaining or servicing it, and before connecting or disconnecting it with a moving brush.
- Do not use an appliance that is damaged or modified. A damaged or modified appliance may exhibit unpredictable behavior resulting in fire, explosion, or risk of injury.
- Do not modify or attempt to repair the appliance except as indicated in the instructions for use and care.
- Do not use the appliance with a damaged attachment (eg: charging base, supply cord etc.). If the appliance or attachment has been dropped, damaged, left outdoors, dropped into water, or is not working as it should, never attempt to operate it. Please have it repaired at an authorized service center.
- Have servicing performed by a qualified repair person using only identical replacement parts. This will ensure that the safety of the appliance is maintained.
- If the supply cord is damaged, it must be replaced by the manufacturer, its service agent or similarly qualified persons in order to avoid a hazard.

Battery and Charging

- For the purpose of recharging the appliance, only use the charging base provided with this appliance. Use only with HCBAE charging base.
- Follow all charging instructions and do not charge the appliance outside of the temperature range specified in the battery as doing so increases the risk of fire.
- Charging base is equipped with drying function and only suitable for drying this appliance's brush.
- Keep the charging base cable away from heated surfaces. Do not handle the charging base plug or appliance with wet hands. To unplug, grasp the charging base plug, rather than the cable.
- Do not pull or carry charging base by cable, use cable as a handle, close door on cable, or pull cable around sharp edges or corners.
- Do not use any non-rechargeable battery pack. Failing to do so may cause the lithium-ion battery to catch fire. This appliance contains batteries that can only be replaced by qualified technicians or after-sales service.
- The lithium-ion battery pack contains substances that are hazardous to the environment. Before disposing of the appliance, please first remove the battery pack, then discard, or recycle it in accordance with local laws and regulations of the country or region it is used in.
- The appliance must be disconnected from the power supply when removing the battery. Keep batteries out of the reach of children. Never put batteries in mouth. If swallowed, contact your physician or local poison control.
- Under abusive conditions, never contact the battery from which the liquid may be ejected. If contact accidentally occurs, rinse with water. If liquid contacts eyes, seek medical help immediately. Liquid ejected from the battery may cause irritation or burns.

- The charging base is capable of charging the 6-cell 5000 mAh battery pack. This charging base should not be used to charge non-rechargeable batteries. Failing to do so may cause the lithium-ion battery to catch fire.
- The charging base is marked with a  icon indicating "Caution: Hot Surface." Do not touch the roller brush, hot water, or heating module of the charging base while self-cleaning with hot water.

Symbols



Class II equipment



Time-lag miniature fuse-link where T 3.15A is the symbol for the time/current characteristic



For indoor use only



Read operator's manual



Caution: Hot Surface



WEEE Information

All products bearing this symbol are waste electrical and electronic equipment (WEEE as in directive 2012/19/EU) which should not be mixed with unsorted household waste. Instead, you should protect human health and the environment by handing over your waste equipment to a designated collection point for the recycling of waste electrical and electronic equipment, appointed by the government or local authorities. Correct disposal and recycling will help prevent potential negative consequences to the environment and human health. Please contact the installer or local authorities for more information about the location as well as terms and conditions of such collection points.

We, Dreame Trading (Tianjin) Co., Ltd., hereby declares that this product complies with the Australian Cyber Security (Security Standards for Smart Devices) Rules 2025. The full text of Statement of Compliance is available at the following internet address:

<https://global.dreame.tech.com>

For detailed e-manual, please go to

<https://global.dreame.tech.com/pages/user-manuals-and-faqs>

Product Overview

Packing List



Handle

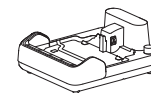

Charging Base

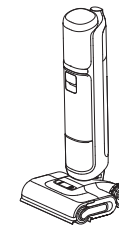

Main Body



Cleaning Brush



Spare Brush Roller



Replacement Filter

Product Overview

Vacuum

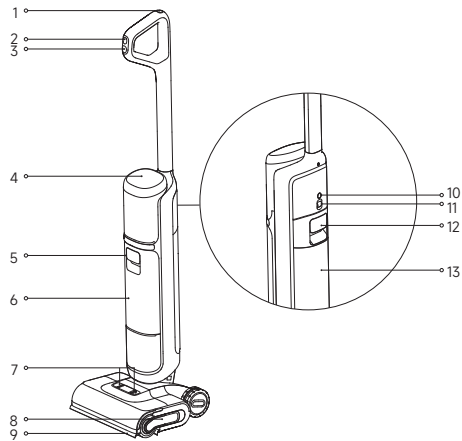

- | | | |
|--------------------------------------|---|---------------------------|
| 1 Self-Cleaning Button | 8 Roller Brush Handle | 11 Omnidirectional Wheel |
| 2 Mode Switch | 9 Lifting Robotic Arm | 12 Used Water Tank Handle |
| 3 Power Switch | 10 Voice Prompt/Wi-Fi Button | 13 Used Water Tank |
| 4 Display Screen | <ul style="list-style-type: none"> · Press briefly to activate the voice prompt or adjust the volume · Press and hold to start/stop Wi-Fi setup | |
| 5 Clean Water Tank Handle | | |
| 6 Clean Water Tank | | |
| 7 Roller Brush Cover Release Buttons | | |

Charging Base

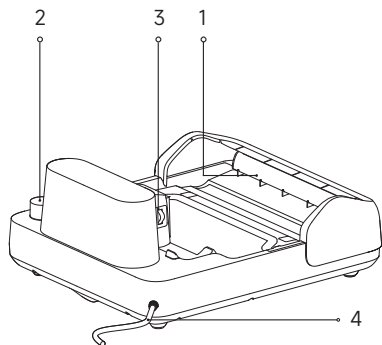

1. Air-Drying Outlet
2. Accessory Storage Slot
3. Charging Contacts
4. Power Cord

Installation & Charging





Fully charge the appliance before first use.

1	2	3
<p>1. Insert the end of the handle vertically into the port on the top of the appliance until it clicks.</p>	<p>2. Place the charging base against a wall on level ground and connect it to a power source.</p>	<p>3. Place the appliance on the charging base. When the screen reaches 100%, charging is complete.</p>
<div style="display: flex; align-items: center;"> <div style="margin-left: 20px;"> <p>* To disassemble, extend a hard object into the hole of the appliance as indicated to press in the contacts and pull the handle upwards at the same time.</p> </div> </div>		

Note:

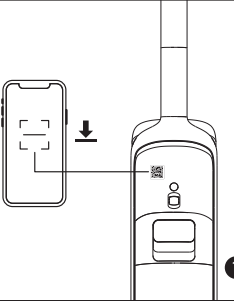
- If there is no operation within 10 minutes of being fully charged, the appliance will enter sleep mode. Please restart the appliance if you need to use it.
- To extend the battery life time, the battery keeps cooling down automatically after you have used the appliance for a long time.

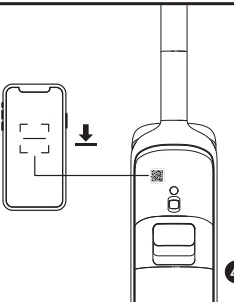

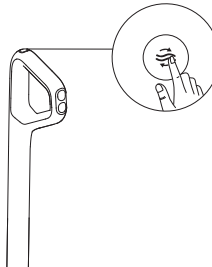

Connecting with Dreamehome App

		
<p>1. Scan the QR code on the appliance, or search "Dreamehome" in the app store to download and install the app.</p>	<p>2. Press the power switch briefly to power on.</p>	<p>3. Press and hold the voice prompt/Wi-Fi button located on the back of the appliance to set up Wi-Fi connection. The Wi-Fi indicator pulses in white, and voice prompt says, "Waiting for the network configuration".</p>
		
<p>4. Open the Dreamehome app and scan the same QR code on the appliance again to add the device. Please follow the prompts to finish the Wi-Fi connection.</p>	<p>* Press and hold the voice prompt/Wi-Fi button and the self-cleaning button for 3 seconds to restore factory settings.</p>	

Note:

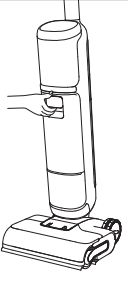
- Only 2.4 GHz Wi-Fi is supported.
- Due to upgrades in the app software, the actual operations may differ from the directions in this manual. Please follow the instructions based on the current app version.
- The appliance will exit the network connection if there is no operation for 10 minutes, or if the network connection fails. To reset Wi-Fi, please repeat the steps above and complete the connection according to the prompts in the app.

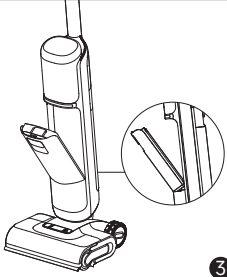
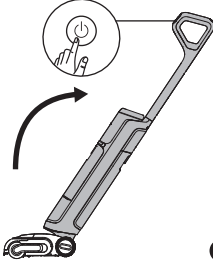
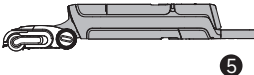
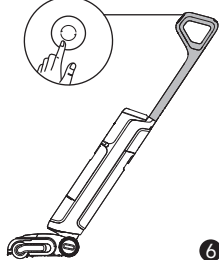
Starting Cleaning

		
<p>1. Pull the clean water tank handle to remove the clean water tank.</p>	<p>2. Open the tank cover and fill the tank with clean water.</p>	<p>3. Reinstall the clean water tank until it clicks.</p>
		
<p>4. Gently step on the floor brush and recline the appliance backwards. Briefly press the power switch  button to start/stop operating.</p>	<p>5. The appliance can lie flat at a 180-degree angle, allowing it to clean under low-profile furniture.</p>	<p>6. Briefly press the mode switch  to switch modes according to your needs.</p>

Note:

- Do not vacuum any foamy liquids.
- The appliance will be suspended in the upright position while running.
- The appliance is suitable for cleaning floors, marble, tiles and other hard surfaces.
- Do not lift or move the appliance while it is operating to prevent dirty water from flowing back into the motor.
- Do not add any liquids other than the officially-approved cleaner. The cleaner can be available on the official online store. Refer to the cleaning solution label for specific usage instructions.

Display Screen



Smart Mode

The appliance will detect the stain level and intelligently adjust the suction power and water flow accordingly.



Hot Water Mode

Suitable for cleaning moderate stains, with the water temperature gradually rising to the hot water level.



Custom Mode

Suction power, water volume, etc. can be adjusted within the APP. The main body will start working according to the settings in the APP.



Suction Mode

Sucks up a large amount of water from the floor.



Self-Cleaning Mode



Drying Mode



Charging Indicator

- Orange Breathing: Battery level ≤ 20% (charging)
- Green Breathing: Battery level > 20% (charging)
- Solid Green: Full charged



Wi-Fi Indicator

- Breathing: To be connected
- Blinking: Connecting/OTA upgrading
- On: Connected



Insufficient water in the clean water tank

Fill the clean water tank.



The used water tank is full

Empty the used water tank.



Roller brush stuck

Clean the roller brush with the provided cleaning brush.



Blocked tube

Clean the tube and dirt sensor.



The roller brush and tube are dirty

Place the appliance back onto the base for self-cleaning.

Emptying the Used Water Tank

<p>1. Pull the used water tank handle to remove the used water tank.</p>	<p>2. Lift the handle of used water tank cover and pull the cover out.</p>	<p>3. Lift the solid waste filter basket and dispose of solid waste.</p>
<p>4. Pour dirty water out and rinse the tank with clean water. Use the cleaning brush to clean the red filter meshes.</p>	<p>5. After cleaning, press the handle of the used water tank cover and insert the cover into the used water tank to reinstall.</p>	<p>6. Insert the bottom of the tank into the main body. Tilt the tank towards the main body until it clicks.</p>

Self-Cleaning with Hot Water &Drying Mode

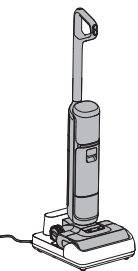
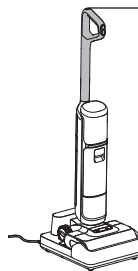
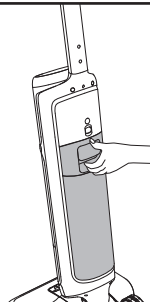

		
<p>1. Place the appliance back onto the base. Ensure that the water in the clean water tank is sufficient for self-cleaning.</p>	<p>2. Upon first startup, briefly press the self-cleaning button to activate the default auto-adjust immersive self-cleaning with hot water and smart drying. For additional self-cleaning modes or to change drying modes, go to the Dreamehome App settings.</p>	<p>3. After self-cleaning is complete, the appliance automatically enters drying mode. Empty the used water tank promptly.</p>

	<p>Press briefly after configuring in the App. Switch between standard and deep-clean immersive self-cleaning with hot water modes via voice prompts.</p>	
	<p>Press and hold for 3 seconds</p>	<p>Enter independent drying mode</p>
	<p>In drying mode, press briefly</p>	<p>Exit drying mode</p>

Care & Maintenance

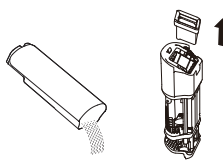

Tips:

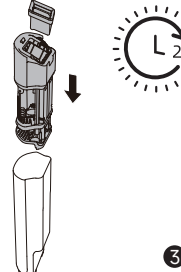
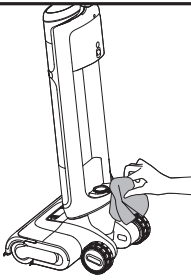
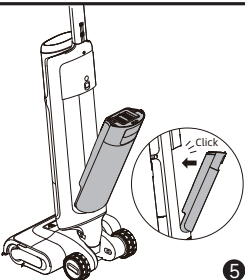
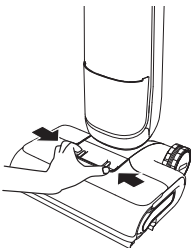
- Turn off the appliance before maintenance. Do not touch the power switch.
- Replace parts if needed. The parts must be replaced by those available from the manufacturer or its service agent.
- If the appliance is not used for an extended period, fully charge it, unplug the power plug, and store the appliance in a cool, low-humidity environment away from direct sunlight. To avoid over-discharge of the battery, charge the appliance at least once every 3 months.

		
<p>1. Pour dirty water out, remove the filter, and rinse the filter tank, tank cover and solid waste filter basket with clean water.</p>	<p>2. Gently knock off the floating dust on the filter surface. When the filter is dirty and needs washing, rinse it with water.</p>	<p>3. After fully drying the filter, reinstall it into the used water tank cover. Insert used water tank cover into the tank.</p>
		
<p>4. Gently wipe the tube with a wet cloth before use. Do not rinse the tube.</p>	<p>5. Insert bottom of tank into main body. Tilt tank towards main body until it clicks.</p>	<p>6. Press the roller brush cover release button inward to remove the cover.</p>

Note:

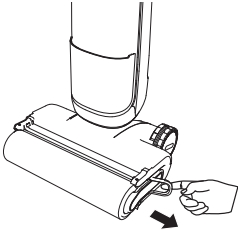
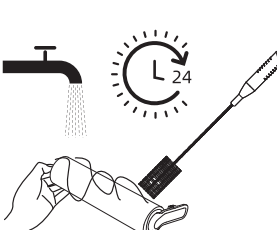
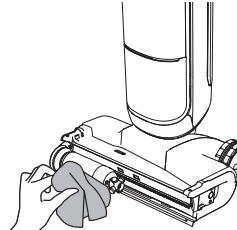
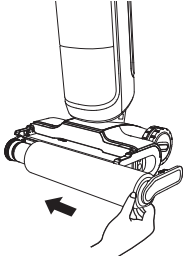
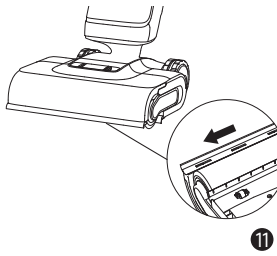
- Self-cleaning can be enabled only when the appliance is being charged and the battery level is more than 20%.
- Do not touch the roller brush, hot water, or heating module of the charging base while self-cleaning with hot water.

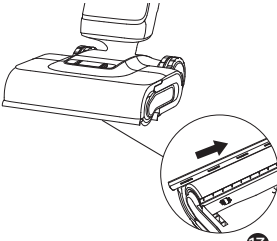
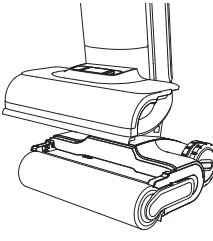
 <p>7</p>	 <p>8</p>	 <p>9</p>
<p>7. Pull up the roller brush handle to remove the roller brush.</p>	<p>8. Remove any hair or debris tangled on the roller brush with the provided cleaning brush. Rinse the roller brush with clean water.</p>	<p>9. Wipe the suction inlet with a dry cloth or wet tissue. Do not rinse the brush assembly with water.</p>
 <p>10</p>	 <p>11</p>	 <p>12</p>
<p>10. After fully drying the roller brush, hold the roller brush handle and reinstall it.</p>	<p>11. Flip the brush roller cover, pull out the lifting robotic arm, and push the scraper to the left to remove it.</p>	<p>12. Rinse the scraper with clean water.</p>
 <p>13</p>	 <p>14</p>	
<p>13. After fully drying the scraper, align it with the slot and push it to the right to reinstall.</p>	<p>14. Align the brush cover with the brush. Press down until cover clicks into place.</p>	

Note:

- Replacing the filter every 3 to 6 months is recommended.
- Clean as needed. Replacing the brush roller every 3 to 6 months is recommended.

Care & Maintenance

Note:

- Replacing the filter every 3 to 6 months is recommended.
- Clean as needed. Replacing the roller brush every 3 to 6 months is recommended.

Troubleshooting

If an error occurs, the appliance will stop working. Please refer to the following table for troubleshooting. If the problem persists, please contact customer service.

Error	Possible Cause	Solution
The appliance does not work	The appliance is out of battery or its battery level is low	Fully charge its battery before use
	The appliance is in the upright position	Recline the appliance backwards
	Blockage activated overheat protection mode	Clear the blockage and wait until the temperature returns normal
	The Used Water Tank is full	Empty the Used Water Tank
	The handle, roller brush, or Used Water Tank is not properly installed	Ensure the handle, roller brush, or Used Water Tank are all properly in place
The appliance charges slowly	The temperature of the battery is too low or too high	Wait until the battery's temperature returns normal
The suction power of the appliance is weak	The filter is clogged	Cleaning the filter
	The suction inlet or tube is blocked by a foreign object	Clean the tube and the suction inlet
The motor is making a strange noise	There is too much used water in the Used Water Tank	Empty the Used Water Tank
	The suction inlet is blocked	Clear any blockage in the suction inlet
The display screen does not light up while charging	The charging base cable is not plugged into the electrical outlet	Make sure the charging base cable is plugged in
	The appliance is not placed onto the charging base properly	Make sure the appliance is placed onto the charging base properly

Troubleshooting

No water is coming out of the appliance	The Clean Water Tank is not properly installed in place, or the water in the Clean Water Tank is insufficient	Re-install or fill the Clean Water Tank
	It takes 30 seconds to dampen the roller brush	Turn on the appliance and check again in 30 seconds
The vent leaks water	A collision or a sharp pull causes water to enter the motor	Move the appliance gently back and forth while it is turned on
	The filter is not completely dry after being cleaned	Dry the filter completely before use
Self-cleaning fails	The roller brush may be jammed by large debris	Open the roller brush cover to check and clean the roller brush
	The appliance is not placed onto the charging base properly	Make sure the appliance is being charged before self-cleaning
	Self-cleaning cannot be enabled if the battery level is lower than 20%	The self-cleaning function can only be enabled when the appliance is being charged and the battery level is more than 20%
	The Used Water Tank is not installed in place, or the Used Water Tank is full	Re-install or empty the Used Water Tank
	The Clean Water Tank is not installed in place, or the water in the Clean Water Tank is insufficient	Re-install or fill the Clean Water Tank
Poor drying performance	The air outlet and air inlet of the charging base may be blocked.	Check and clear the blockage of air outlet and air inlet.
Wi-Fi Connection fails	The Wi-Fi network password is incorrect.	Make sure the password used to connect to your Wi-Fi network is correct.
	The appliance does not support a 5 GHz Wi-Fi connection.	Make sure the robot is connected to a 2.4 GHz Wi-Fi connection.
	The Wi-Fi signal is weak.	Make sure the robot is in an area with good Wi-Fi coverage.
	The appliance may not be ready to be configured.	Please exit and re-enter the app, and then try again as instructed.

For additional services, Australian customers may contact us at support.au@dreame.tech, and New Zealand customers may contact us at support.nz@dreame.tech.

Website: <https://dreame.com.au/>

Error Prompts and Solutions

If the appliance is not working properly, the screen display will show an error message. Please refer to the troubleshooting table to find your solution.

Troubleshooting Code	Possible Cause	Solution
E1-E7	Error	Restart the appliance for troubleshooting. If the problem persists, please contact customer service
F1-F6		
H1-H6		
H7	Battery overheating	Wait until the battery's temperature returns normal

Specifications

Vacuum			
Model	HHR48A	Charging Time	approx. 4 hours
Rated Voltage	21.6 V $\overline{\text{---}}$	Rated Power	400 W
Clean Water Tank Capacity	800 mL	Used Water Tank Capacity	650 mL
Charging Base			
Model	HCBAE	Rated Power Input*	650 W
Rated Input	220-240 V \sim 50 - 60 Hz	Rated Output	27.0 V $\overline{\text{---}}$ 1.6 A

Under normal use of condition, this equipment should be kept a separation distance of at least 20cm between the antenna and the body of the user.

Battery Disposal and Removal

The built-in lithium-ion battery contains substances that are hazardous to the environment. Before disposing of the battery, make sure the battery is removed by qualified technicians and discarded at an appropriate recycling facility.

- the battery must be removed from the appliance before it is scrapped;
- the appliance must be disconnected from the supply mains when removing the battery;
- the battery is to be disposed of safely.

Removal Guide

1. Remove the screw plug at the top of the back of the appliance and remove the screw by a screwdriver.
2. Use a proper tool to remove the display assembly and disconnect the cables.
3. Use a screwdriver to remove all the fixing screws from the body.
4. Remove the screws on the battery pack assembly and then remove the battery cover.
5. Disconnect the battery pack's connector cables and remove the battery from the battery pack assembly.

CAUTION:

- Before removing the battery, disconnect the power and run out the battery as much as possible.
- Unneeded batteries should be discarded at an appropriate recycling facility.
- Do not expose to high temperature environment to avoid risks of explosion.
- Under abusive conditions, liquid may be ejected from the battery. If contact occurs, flush with water and seek medical help.

Warranty

1. Dreame is liable to the consumer for any lack of conformity in material or workmanship not detectable at the time of the purchase.
2. Warranty period: please refer to the customer service office for more information. If the territory where the consumer is located has different regulations, local regulations prevail.
3. The warranty will not be applicable in the following cases:
 - a) Issues due to carelessness, use, or installation that does not comply with the instructions provided by Dreame.
 - b) Tampering and/or modifications of the product by entities or individuals not expressly authorized by Dreame.
 - c) Damage due to accidental causes and/or negligence on the part of the consumer, with particular reference to external parts.
 - d) Parts subject to wear that do not have manufacturing defects.
 - e) No valid purchasing document (receipt, invoice, or other) is provided to certify the date the product was purchased.
 - f) The model and/or numbers of the product on the purchase certificate is not consistent with the model and/or numbers shown on the product.
4. For more warranty information, please refer to the official Dreame website: <https://dreame.com.au>

DREAME
追觅

Statement of Compliance

Product name: Wet and Dry Vacuum Floor Washer
 Model/Type: HHR48F
 Batch/serial no.: XXXXXX###ZZYYYYYAB
 (the six X represents the project code/ the three # represents the date code /the two Z represents the area code/the five Y represents the natural number starting from 00001 / AB represents the manufacturing factory code)

Manufacturer's Name: Dreame Trading (Tianjin) Co., Ltd.
 Manufacturer's Address: Room 2112-1-1, South District, Finance and Trade Center, No.6975 Yazhou Road, Dongjiang Bonded Port Area, Tianjin Pilot Free Trade Zone, 300463 Tianjin, PEOPLE'S REPUBLIC OF CHINA

The defined support period: End date: 2029.03.04

We, Dreame Trading (Tianjin) Co., Ltd. declare under our sole responsibility that the above referenced product complies with the Cyber Security (Security Standards for Smart Devices) Rules 2025 and relevant standards, details as follow:

Regulation Requirements	Standards
The applicable security requirements in Schedule 1;	NA
Provision 5.1-1	ETSI EN 303 645 V2.1.1 (2020-06)
Provision 5.1-2	
Provision 5.2-1	
Provision 5.3-13	

Person responsible for making this declaration:

Name, Surname: Yu Qian

(Signature) Yu Qian

Position/Title: Lab. Manager

Place: Suzhou, Jiangsu

Date: 2025.12.19



